

Part Number: PT278-48170

Kit Contents

Item #	Quantity Reqd.	Description
1	1	Front Crossbar Assembly
2	1	Rear Crossbar Assembly
3	2	RH Crossbar Covers
4	2	LH Crossbar Covers
5	1	Hardware Bag

Recommended Sequence of Application

Item #	Accessory
1	
2	
3	

*Mandatory

Hardware Bag Contents

Item #	Quantity Reqd.	Description
1	1	Torque Tool
2	4	Tethers
3	4	Anti-Rotation Caps
4	1	Users Guide
5	2	Load Capacity Label w/ White Lettering (165 lb / 75 kg)
6	2	Load Capacity Label w/ Black Lettering (165 lb / 75 kg)

Vehicle Service Parts (may be required for reassembly)

Item #	Quantity Reqd.	Description
1		
2		
3		

Additional Items Required For Installation

Item #	Quantity Reqd.	Description
1		
2		
3		

Conflicts

None

Recommended Tools

Personal & Vehicle Protection	Notes
Safety Glasses	
Safety Gloves	
Vehicle Protection	Cloth
Wrist & Belt Buckle Protection	
Special Tools	Notes
Plastic trim removal tool	
Installation Tools	Notes
13mm Socket	
Torque Wrench	0-75 lbf-in
Special Chemicals	Notes

General Applicability

2014 and newer Highlander/HV

Legend

 **STOP:** Damage to the vehicle may occur. Do not proceed until process has been complied with.

 **OPERATOR SAFETY:** Use caution to avoid risk of injury.

 **CAUTION:** A process that must be carefully observed in order to reduce the risk of damage to the accessory/vehicle and to ensure a quality installation.

 **TOOLS & EQUIPMENT:** Used in Figures calls out the specific tools and equipment recommended for this process.

 **REVISION MARK:** This mark highlights a change in installation with respect to previous issue.

 **SAFETY TORQUE:** This mark indicates that torque is related to safety.

Procedure

Care must be taken when installing this accessory to ensure damage does not occur to the vehicle. The installation of this accessory should follow approved guidelines to ensure a quality installation.

These guidelines can be found in the "Accessory Installation Practices" document.

This document covers such items as:-

- Vehicle Protection (use of covers and blankets, cleaning chemicals, etc.).
- Safety (eye protection, rechecking torque procedure, etc.).
- Vehicle Disassembly/Reassembly (panel removal, part storage, etc.).
- Electrical Component Disassembly/Reassembly (battery disconnection, connector removal, etc.).

Please see your Toyota dealer for a copy of this document.

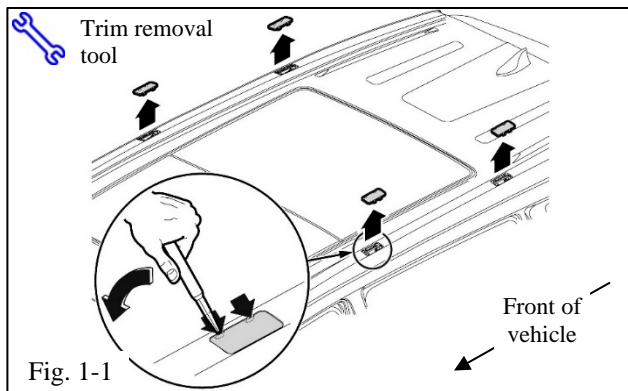

1. Remove the Side Rail Covers.

- ⚠ (a) Use a plastic trim removal tool to carefully remove the 4 trim covers by pressing the tabs and prying up in 4 places (Fig. 1-1).
- (b) Retain the covers for future use.

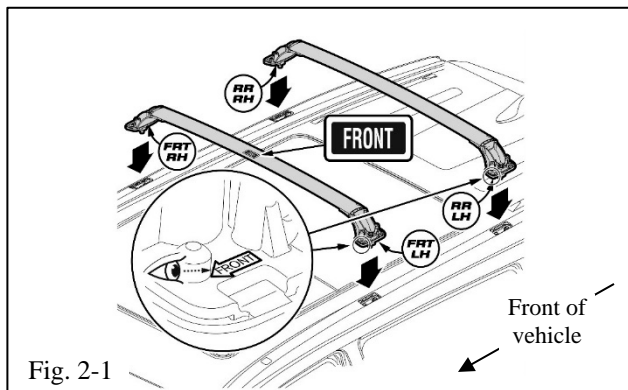

2. Install the Crossbars.

- ⚠ (a) Make sure the arrows on the crossbar end supports are pointing toward the front of the vehicle (Fig. 2-1).

⚠ NOTE:

- The front crossbar has a "FRONT" label.
- The front and rear, LH and RH, crossbars are molded into the support pad bottom.

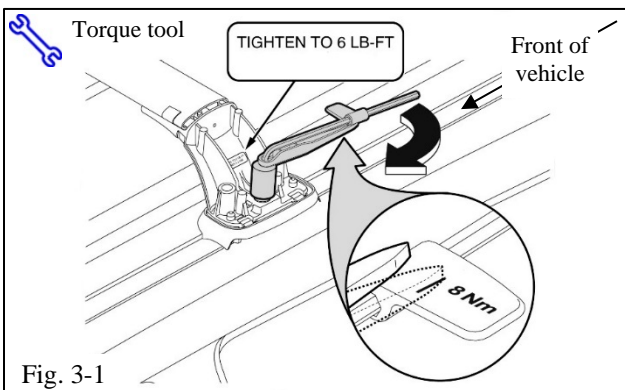

⚠ (b) Make sure the rectangle spacers are oriented properly.

(1) The spacer should sit down into the recess (Fig. 2-2).

(2) The spacer should **not** sit above it (Fig. 2-3).

(c) Make sure the orientation is correct. Incorrect orientation will create a large space between the crossbar and the vehicle.

3. Secure the Crossbars.

⚠ (a) Use the tool provided in the kit or a torque wrench with a 13mm socket, and tighten the bolt to 8 N·m (71 in·lbf) (4 places) (Fig. 3-1).

Torque: 8 N·m (71 in·lbf)

⚠ (b) Verify all of the supports are snug and properly fitted into the side rail (4 places).

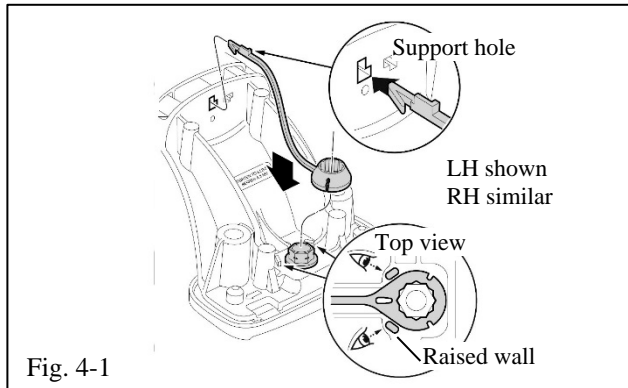

4. Attach the Anti-rotation Caps to the Crossbars (4 Places).

- (a) Carefully open the hardware bag and remove the tethers (Fig. 4-1).
- (b) Install the tether end of the anti-rotation cap into the crossbar support.
- (c) Install a cap over the crossbar bolt.

⚠ NOTE:

- Verify the proper orientation of the tether into the hole specified in Fig. 4-1.
- Verify the tether is fully engaged and locked into the support.
- Verify the caps are fully engaged.
- Verify the caps are centered between the 2 small raised walls on the support.

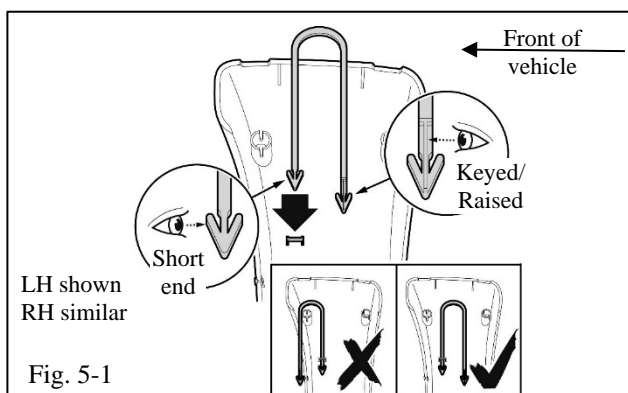

5. Attach the Tethers to the Crossbar Covers.

- (a) Install the 4 tethers on the covers. (2 RH, 2 LH) (Fig. 5-1).
- (b) Install the short end of the tether through the loop on the cover.

⚠ NOTE:

- Verify the tether is centered in the cover.
- Verify the tether is fully engaged and locked into the cover.

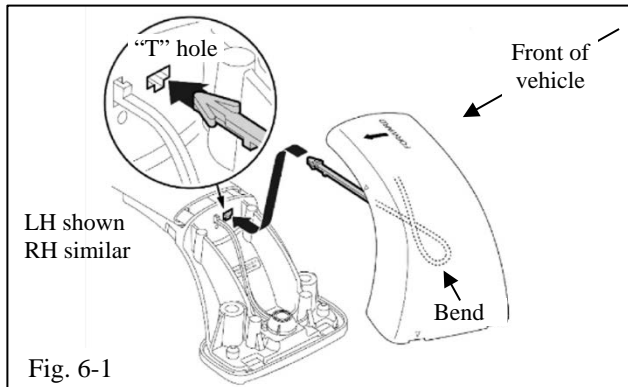

6. Attach the Tethers to the Crossbars.

- (a) Install the 4 tethers (2 RH, 2 LH) with covers on to the crossbar supports. The tether is flat and must be bent during installation (Fig. 6-1).

NOTE:

- Verify the proper orientation of the keyed/raised end of the tether when inserting into the “T” shape hole in the crossbar support (Fig. 6-1).
- Verify the tether is fully engaged and locked into the support.

7. Install the Crossbar Covers.

- (a) Install the crossbar covers (4 places) (Fig. 7-1). Line up the cover posts with the holes in the supports. Press down firmly (Fig. 7-1).

- NOTE:** Make sure the covers are fully engaged at each location marked with a triangle (16 places) (Fig. 7-2).

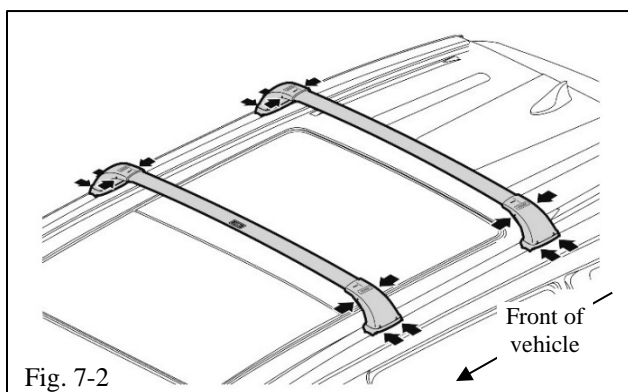
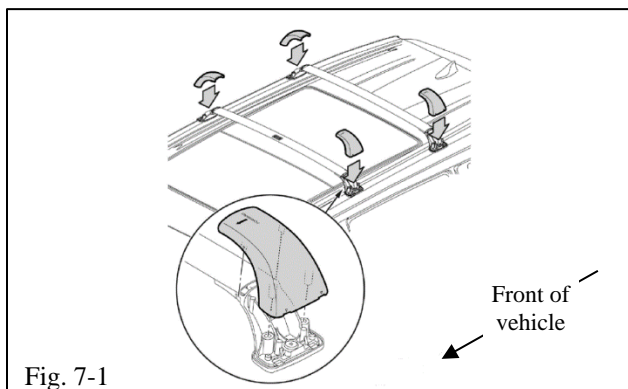

8. Install the Load Capacity Label.

- (a) Remove the load capacity labels from the hardware bag.

 **NOTE:**

- Select a load capacity label with font color contrasting to the rail/garnish, so that the label is legible. (e.g. select a label with black font for a silver rail).
- Maximum load indicated on the label is 165 lb (75 kg).

- (b) Remove one of the load capacity labels from the protective backing.

- (c) Orient the label so that the text is legible.

- (d) Place it on the top, center of the rail/garnish, 20mm (0.79 inches) from the front pad (Fig. 8-1). Firmly apply the load capacity label by applying pressure from one end of the label to the opposite end of the label.

- (e) Repeat Steps 8(b) – 8(d) on the opposite roof rail.

- (f) Discard the two unused load labels.

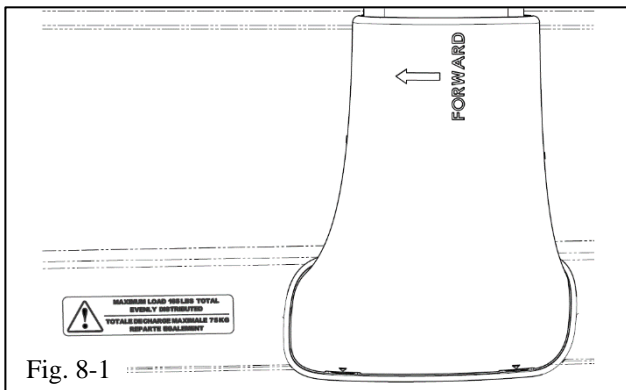

9. Complete the Installation.

-  (a) Place the side rail covers removed in Step 1(b) and the crossbar user's manual and torque tool in the polybag.
- (b) Place the polybag with the side rail covers, crossbar user's manual, and the torque tool in the glove box.

Checklist - these points **MUST** be checked to ensure a quality installation.

<u>Check:</u>	<u>Look For:</u>
<p><u>Accessory Function Checks</u></p> <ul style="list-style-type: none"><input type="checkbox"/> Ensure the crossbars are secure and in the correct position<input type="checkbox"/> Side rail covers, crossbar user's guide and torque tool<input type="checkbox"/> Crossbar cover engagement<input type="checkbox"/> Load Label	<p>Front crossbar has "FRONT" label.</p> <p>Side rail covers, user's guide and torque tool are inside the vehicle glove box</p> <p>Ensure crossbar covers are fully engaged.</p> <p>Ensure the load labels are installed on the rail and legible (both sides).</p> <p>Maximum load indicated on the label is 165 lb (75 kg).</p>
<p><u>Vehicle Function Checks</u></p> <ul style="list-style-type: none"><input type="checkbox"/>	
<p><u>Vehicle Appearance Check</u></p> <ul style="list-style-type: none"><input type="checkbox"/> After the accessory installation, perform a visual inspection.	<p>Ensure no damage (including scuffs and scratches) was caused during the installation process. (For PPO installations, refer to TMS Accessory Quality Shipping Standard.)</p>